

Core Slice Components

RGB LED

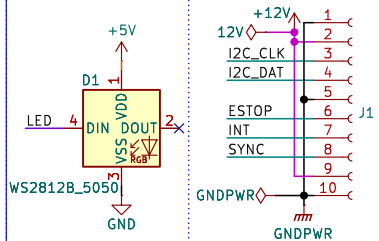

5V Switching Supply

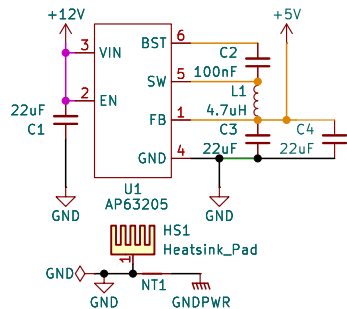

Arduino Nano

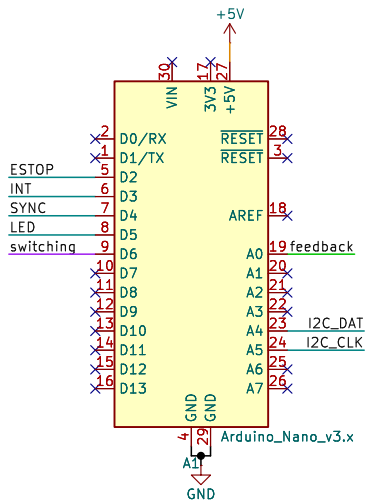

Mounting Holes

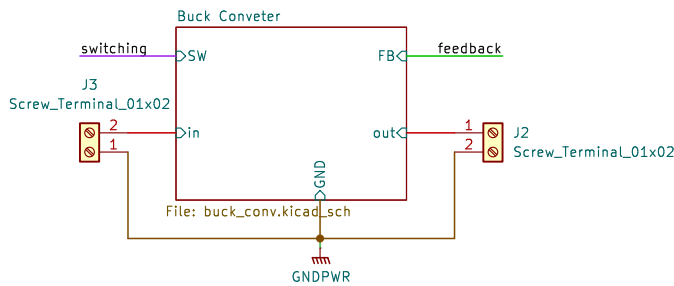
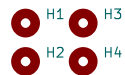

Sheet: /
File: BREAD_Slice.kicad_sch

Title:

Size: A4
KiCad E.D.A. 9.0.7

Date:

Rev:

Id: 1/2

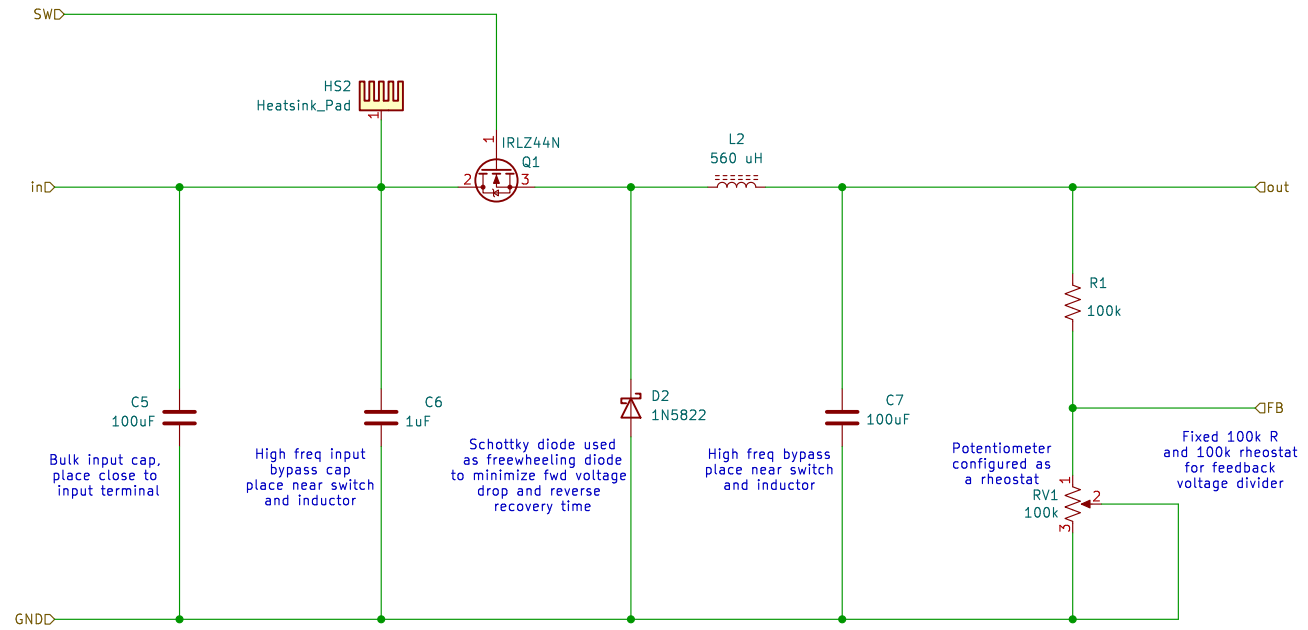

Sheet: /Buck Converter/
File: buck_conv.kicad_sch

Title:

Size: A4

Date:

KiCad E.D.A. 9.0.7

Rev:

Id: 2/2